

Jameco Part Number 23851

LM139/LM239/LM339/LM2901/LM3302

Low Power Low Offset Voltage Quad Comparators

General Description

The LM139 series consists of four independent precision voltage comparators with an offset voltage specification as low as 2 mV max for all four comparators. These were designed specifically to operate from a single power supply over a wide range of voltages. Operation from split power supplies is also possible and the low power supply current drain is independent of the magnitude of the power supply voltage. These comparators also have a unique characteristic in that the input common-mode voltage range includes ground, even though operated from a single power supply voltage.

Application areas include limit comparators, simple analog to digital converters; pulse, squarewave and time delay generators; wide range VCO; MOS clock timers; multivibrators and high voltage digital logic gates. The LM139 series was designed to directly interface with TTL and CMOS. When operated from both plus and minus power supplies, they will directly interface with MOS logic— where the low power drain of the LM339 is a distinct advantage over standard comparators.

Features

- Wide supply voltage range
- LM139/139A Series 2 to 36 V_{DC} or ±1 to ±18 V_{DC}
- LM2901: 2 to 36 V_{DC} or ±1 to ±18 V_{DC}
- LM3302: 2 to 28 V_{DC} or ±1 to ±14 V_{DC}
- Very low supply current drain (0.8 mA) — independent of supply voltage
- Low input biasing current: 25 nA
- Low input offset current: ±5 nA
- Offset voltage: ±3 mV
- Input common-mode voltage range includes GND
- Differential input voltage range equal to the power supply voltage
- Low output saturation voltage: 250 mV at 4 mA
- Output voltage compatible with TTL, DTL, ECL, MOS and CMOS logic systems

Advantages

- High precision comparators
- Reduced V_{OS} drift over temperature
- Eliminates need for dual supplies
- Allows sensing near GND
- Compatible with all forms of logic
- Power drain suitable for battery operation

One-Shot Multivibrator with Input Lock Out

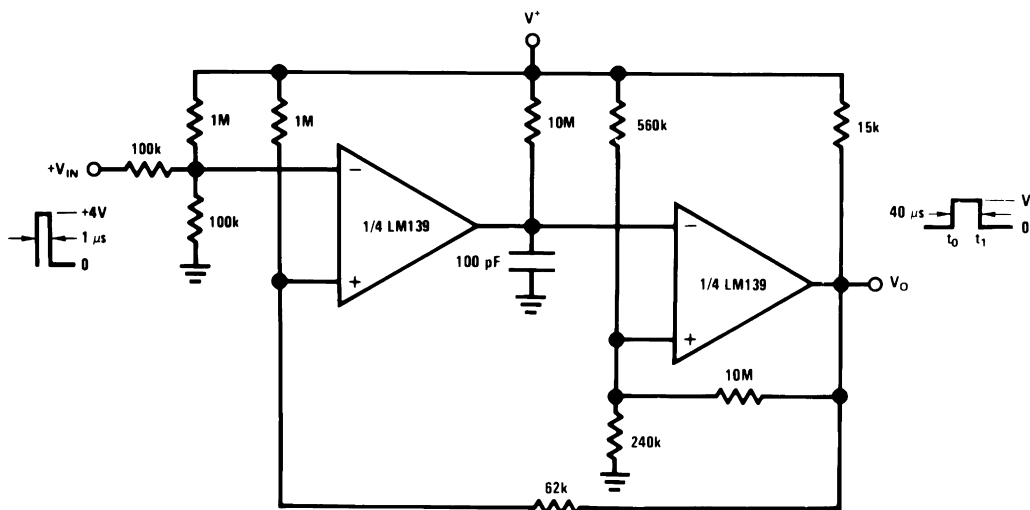

DS005706-12

Absolute Maximum Ratings (Note 10)

If Military/Aerospace specified devices are required, please contact the National Semiconductor Sales Office/Distributors for availability and specifications.

	LM139/LM239/LM339 LM139A/LM239A/LM339A LM2901	LM3302
Supply Voltage, V^+	$36 V_{DC}$ or $\pm 18 V_{DC}$	$28 V_{DC}$ or $\pm 14 V_{DC}$
Differential Input Voltage (Note 8)	$36 V_{DC}$	$28 V_{DC}$
Input Voltage	$-0.3 V_{DC}$ to $+36 V_{DC}$	$-0.3 V_{DC}$ to $+28 V_{DC}$
Input Current ($V_{IN} < -0.3 V_{DC}$), (Note 3)	50 mA	50 mA
Power Dissipation (Note 1)		
Molded DIP	1050 mW	1050 mW
Cavity DIP	1190 mW	
Small Outline Package	760 mW	
Output Short-Circuit to GND, (Note 2)	Continuous	Continuous
Storage Temperature Range	-65°C to $+150^{\circ}\text{C}$	-65°C to $+150^{\circ}\text{C}$
Lead Temperature (Soldering, 10 seconds)	260°C	260°C
Operating Temperature Range		-40°C to $+85^{\circ}\text{C}$
LM339/LM339A	0°C to $+70^{\circ}\text{C}$	
LM239/LM239A	-25°C to $+85^{\circ}\text{C}$	
LM2901	-40°C to $+85^{\circ}\text{C}$	
LM139/LM139A	-55°C to $+125^{\circ}\text{C}$	
Soldering Information		
Dual-In-Line Package		
Soldering (10 seconds)	260°C	260°C
Small Outline Package		
Vapor Phase (60 seconds)	215°C	215°C
Infrared (15 seconds)	220°C	220°C
See AN-450 "Surface Mounting Methods and Their Effect on Product Reliability" for other methods of soldering surface mount devices.		
ESD rating (1.5 k Ω in series with 100 pF)	600V	600V

Electrical Characteristics

($V^+ = 5 V_{DC}$, $T_A = 25^{\circ}\text{C}$, unless otherwise stated)

Parameter	Conditions	LM139A			LM239A, LM339A			LM139			Units
		Min	Typ	Max	Min	Typ	Max	Min	Typ	Max	
Input Offset Voltage	(Note 9)	1.0	2.0		1.0	2.0		2.0	5.0		mV _{DC}
Input Bias Current	$I_{IN(+)}$ or $I_{IN(-)}$ with Output in Linear Range, (Note 5), $V_{CM} = 0V$	25	100		25	250		25	100		nA _{DC}
Input Offset Current	$I_{IN(+)} - I_{IN(-)}$, $V_{CM} = 0V$	3.0	25		5.0	50		3.0	25		nA _{DC}
Input Common-Mode Voltage Range	$V^+ = 30 V_{DC}$ (LM3302, $V^+ = 28 V_{DC}$) (Note 6)	0	$V^+ - 1.5$		0	$V^+ - 1.5$		0	$V^+ - 1.5$		V _{DC}
Supply Current	$R_L = \infty$ on all Comparators, $R_L = \infty$, $V^+ = 36V$, (LM3302, $V^+ = 28 V_{DC}$)	0.8	2.0		0.8	2.0		0.8	2.0		mA _{DC}
					1.0	2.5		1.0	2.5		mA _{DC}
Voltage Gain	$R_L \geq 15 k\Omega$, $V^+ = 15 V_{DC}$, $V_o = 1 V_{DC}$ to $11 V_{DC}$	50	200		50	200		50	200		V/mV
Large Signal Response Time	$V_{IN} = \text{TTL Logic Swing}$, $V_{REF} = 1.4 V_{DC}$, $V_{RL} = 5 V_{DC}$, $R_L = 5.1 k\Omega$	300			300			300			ns
Response Time	$V_{RL} = 5 V_{DC}$, $R_L = 5.1 k\Omega$, (Note 7)	1.3			1.3			1.3			μs

Electrical Characteristics (Continued)(V⁺ = 5 V_{DC}, T_A = 25°C, unless otherwise stated)

Parameter	Conditions	LM139A		LM239A, LM339A			LM139			Units	
		Min	Typ	Max	Min	Typ	Max	Min	Typ		Max
Output Sink Current	V _{IN(-)}} = 1 V _{DC} , V _{IN(+)} = 0, V _O ≤ 1.5 V _{DC}	6.0	16		6.0	16		6.0	16		mA _{DC}
Saturation Voltage	V _{IN(-)}} = 1 V _{DC} , V _{IN(+)} = 0, I _{SINK} ≤ 4 mA		250	400		250	400		250	400	mV _{DC}
Output Leakage Current	V _{IN(+)} = 1 V _{DC} , V _{IN(-)} = 0, V _O = 5 V _{DC}		0.1			0.1			0.1		nA _{DC}

Electrical Characteristics(V⁺ = 5 V_{DC}, T_A = 25°C, unless otherwise stated)

Parameter	Conditions	LM239, LM339			LM2901			LM3302			Units
		Min	Typ	Max	Min	Typ	Max	Min	Typ	Max	
Input Offset Voltage	(Note 9)		2.0	5.0		2.0	7.0		3	20	mV _{DC}
Input Bias Current	I _{IN(+)} or I _{IN(-)} with Output in Linear Range, (Note 5), V _{CM} = 0V		25	250		25	250		25	500	nA _{DC}
Input Offset Current	I _{IN(+)} - I _{IN(-)} , V _{CM} = 0V		5.0	50		5	50		3	100	nA _{DC}
Input Common-Mode Voltage Range	V ⁺ = 30 V _{DC} (LM3302, V ⁺ = 28 V _{DC}) (Note 6)	0		V ⁺ - 1.5	0		V ⁺ - 1.5	0		V ⁺ - 1.5	V _{DC}
Supply Current	R _L = ∞ on all Comparators, R _L = ∞, V ⁺ = 36V, (LM3302, V ⁺ = 28 V _{DC})		0.8	2.0		0.8	2.0		0.8	2.0	mA _{DC}
			1.0	2.5		1.0	2.5		1.0	2.5	mA _{DC}
Voltage Gain	R _L ≥ 15 kΩ, V ⁺ = 15 V _{DC} , V _O = 1 V _{DC} to 11 V _{DC}	50	200		25	100		2	30		V/mV
Large Signal Response Time	V _{IN} = TTL Logic Swing, V _{REF} = 1.4 V _{DC} , V _{RL} = 5 V _{DC} , R _L = 5.1 kΩ,		300			300			300		ns
Response Time	V _{RL} = 5 V _{DC} , R _L = 5.1 kΩ, (Note 7)		1.3			1.3			1.3		μs
Output Sink Current	V _{IN(-)}} = 1 V _{DC} , V _{IN(+)} = 0, V _O ≤ 1.5 V _{DC}	6.0	16		6.0	16		6.0	16		mA _{DC}
Saturation Voltage	V _{IN(-)}} = 1 V _{DC} , V _{IN(+)} = 0, I _{SINK} ≤ 4 mA		250	400		250	400		250	500	mV _{DC}
Output Leakage Current	V _{IN(+)} = 1 V _{DC} , V _{IN(-)} = 0, V _O = 5 V _{DC}		0.1			0.1			0.1		nA _{DC}

Electrical Characteristics(V⁺ = 5.0 V_{DC}, (Note 4))

Parameter	Conditions	LM139A		LM239A, LM339A			LM139			Units	
		Min	Typ	Max	Min	Typ	Max	Min	Typ		Max
Input Offset Voltage	(Note 9)			4.0		4.0			9.0		mV _{DC}
Input Offset Current	I _{IN(+)} - I _{IN(-)} , V _{CM} = 0V			100		150			100		nA _{DC}
Input Bias Current	I _{IN(+)} or I _{IN(-)} with Output in Linear Range, V _{CM} = 0V (Note 5)			300		400			300		nA _{DC}
Input Common-Mode Voltage Range	V ⁺ = 30 V _{DC} (LM3302, V ⁺ = 28 V _{DC}) (Note 6)	0		V ⁺ - 2.0	0		V ⁺ - 2.0	0		V ⁺ - 2.0	V _{DC}
Saturation Voltage	V _{IN(-)}} = 1 V _{DC} , V _{IN(+)} = 0, I _{SINK} ≤ 4 mA			700		700			700		mV _{DC}

Electrical Characteristics (Continued)

($V^+ = 5.0 V_{DC}$, (Note 4))

Parameter	Conditions	LM139A		LM239A, LM339A			LM139		Units	
		Min	Typ	Max	Min	Typ	Max	Min		Typ
Output Leakage Current	$V_{IN(+)}=1 V_{DC}$, $V_{IN(-)}=0$, $V_O=30 V_{DC}$, (LM3302, $V_O=28 V_{DC}$)			1.0			1.0			μA_{DC}
Differential Input Voltage	Keep all V_{IN} 's $\geq 0 V_{DC}$ (or V^- , if used), (Note 8)			36			36			V_{DC}

Electrical Characteristics

($V^+ = 5.0 V_{DC}$, (Note 4))

Parameter	Conditions	LM239, LM339			LM2901			LM3302			Units
		Min	Typ	Max	Min	Typ	Max	Min	Typ	Max	
Input Offset Voltage	(Note 9)			9.0	9	15			40		mV_{DC}
Input Offset Current	$I_{IN(+)} - I_{IN(-)}$, $V_{CM}=0V$			150	50	200			300		nA_{DC}
Input Bias Current	$I_{IN(+)}$ or $I_{IN(-)}$ with Output in Linear Range, $V_{CM}=0V$ (Note 5)			400	200	500			1000		nA_{DC}
Input Common-Mode Voltage Range	$V^+=30 V_{DC}$ (LM3302, $V^+=28$ V_{DC}) (Note 6)			$V^+-2.0$	0	$V^+-2.0$	0		$V^+-2.0$		V_{DC}
Saturation Voltage	$V_{IN(-)}=1 V_{DC}$, $V_{IN(+)}=0$, $I_{SINK} \leq 4 mA$			700	400	700			700		mV_{DC}
Output Leakage Current	$V_{IN(+)}=1 V_{DC}$, $V_{IN(-)}=0$, $V_O=30 V_{DC}$, (LM3302, $V_O=28$ V_{DC})			1.0			1.0				μA_{DC}
Differential Input Voltage	Keep all V_{IN} 's $\geq 0 V_{DC}$ (or V^- , if used), (Note 8)			36			36		28		V_{DC}

Note 1: For operating at high temperatures, the LM339/LM339A, LM2901, LM3302 must be derated based on a 125°C maximum junction temperature and a thermal resistance of 95°C/W which applies for the device soldered in a printed circuit board, operating in a still air ambient. The LM239 and LM139 must be derated based on a 150°C maximum junction temperature. The low bias dissipation and the "ON-OFF" characteristic of the outputs keeps the chip dissipation very small ($P_D \leq 100 mW$), provided the output transistors are allowed to saturate.

Note 2: Short circuits from the output to V^+ can cause excessive heating and eventual destruction. When considering short circuits to ground, the maximum output current is approximately 20 mA independent of the magnitude of V^+ .

Note 3: This input current will only exist when the voltage at any of the input leads is driven negative. It is due to the collector-base junction of the input PNP transistors becoming forward biased and thereby acting as input diode clamps. In addition to this diode action, there is also lateral NPN parasitic transistor action on the IC chip. This transistor action can cause the output voltages of the comparators to go to the V^+ voltage level (or to ground for a large overdrive) for the time duration that an input is driven negative. This is not destructive and normal output states will re-establish when the input voltage, which was negative, again returns to a value greater than $-0.3 V_{DC}$ (at 25°C).

Note 4: These specifications are limited to $-55^\circ C \leq T_A \leq +125^\circ C$, for the LM139/LM139A. With the LM239/LM239A, all temperature specifications are limited to $-25^\circ C \leq T_A \leq +85^\circ C$, the LM339/LM339A temperature specifications are limited to $0^\circ C \leq T_A \leq +70^\circ C$, and the LM2901, LM3302 temperature range is $-40^\circ C \leq T_A \leq +85^\circ C$.

Note 5: The direction of the input current is out of the IC due to the PNP input stage. This current is essentially constant, independent of the state of the output so no loading change exists on the reference or input lines.

Note 6: The input common-mode voltage or either input signal voltage should not be allowed to go negative by more than 0.3V. The upper end of the common-mode voltage range is $V^+ - 1.5V$ at 25°C, but either or both inputs can go to $+30 V_{DC}$ without damage (25V for LM3302), independent of the magnitude of V^+ .

Note 7: The response time specified is a 100 mV input step with 5 mV overdrive. For larger overdrive signals 300 ns can be obtained, see typical performance characteristics section.

Note 8: Positive excursions of input voltage may exceed the power supply level. As long as the other voltage remains within the common-mode range, the comparator will provide a proper output state. The low input voltage state must not be less than $-0.3 V_{DC}$ (or $0.3 V_{DC}$ below the magnitude of the negative power supply, if used) (at 25°C).

Note 9: At output switch point, $V_O = 1.4 V_{DC}$, $R_S = 0\Omega$ with V^+ from $5 V_{DC}$ to $30 V_{DC}$; and over the full input common-mode range ($0 V_{DC}$ to $V^+ - 1.5 V_{DC}$), at 25°C. For LM3302, V^+ from $5 V_{DC}$ to $28 V_{DC}$.

Note 10: Refer to RETS139AX for LM139A military specifications and to RETS139X for LM139 military specifications.

Typical Performance Characteristics LM139/LM239/LM339, LM139A/LM239A/LM339A, LM3302

Supply Current

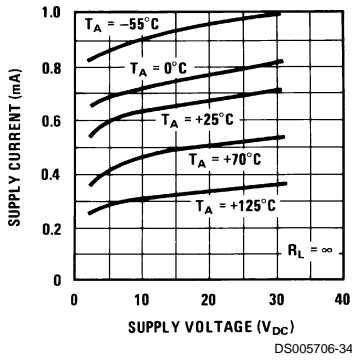

Input Current

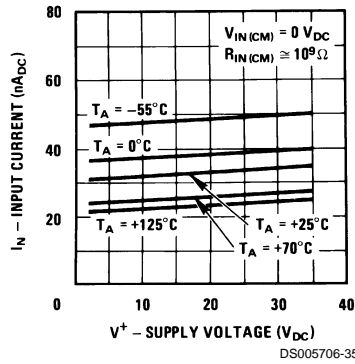

Output Saturation Voltage

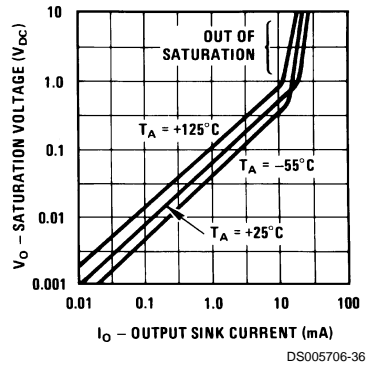

Response Time for Various Input Overdrives — Negative Transition

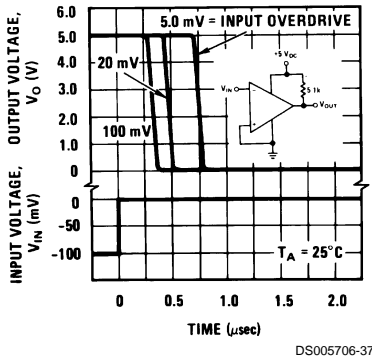

Response Time for Various Input Overdrives — Positive Transition

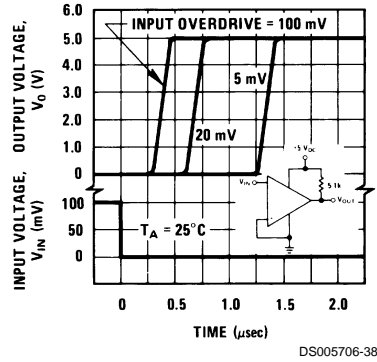

Typical Performance Characteristics LM2901

Supply Current

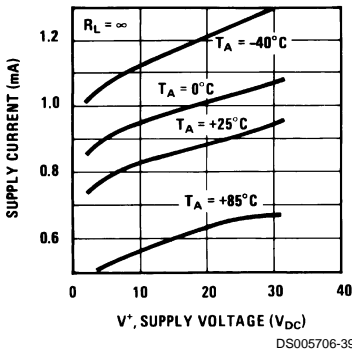

Input Current

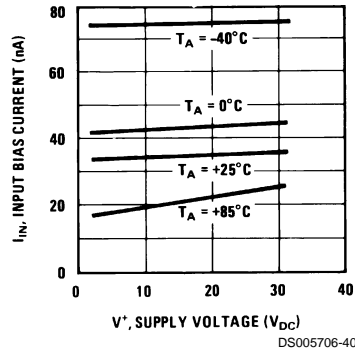

Output Saturation Voltage

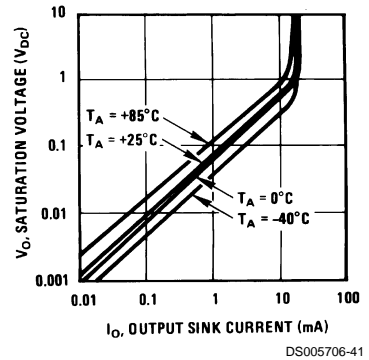

Typical Performance Characteristics LM2901 (Continued)

Response Time for Various Input Overdrives — Negative Transition

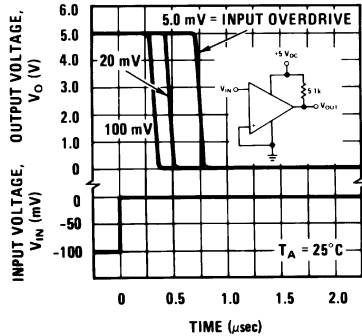

DS005706-42

Response Time for Various Input Overdrives-Positive Transition

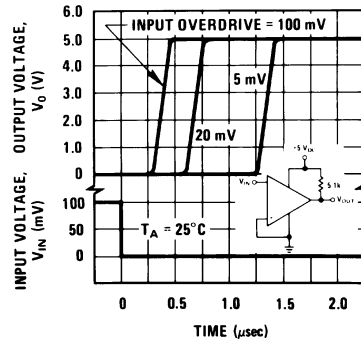

DS005706-43

Application Hints

The LM139 series are high gain, wide bandwidth devices which, like most comparators, can easily oscillate if the output lead is inadvertently allowed to capacitively couple to the inputs via stray capacitance. This shows up only during the output voltage transition intervals as the comparator changes states. Power supply bypassing is not required to solve this problem. Standard PC board layout is helpful as it reduces stray input-output coupling. Reducing this input resistors to $< 10 \text{ k}\Omega$ reduces the feedback signal levels and finally, adding even a small amount (1 to 10 mV) of positive feedback (hysteresis) causes such a rapid transition that oscillations due to stray feedback are not possible. Simply socketing the IC and attaching resistors to the pins will cause input-output oscillations during the small transition intervals unless hysteresis is used. If the input signal is a pulse waveform, with relatively fast rise and fall times, hysteresis is not required.

All pins of any unused comparators should be tied to the negative supply.

The bias network of the LM139 series establishes a drain current which is independent of the magnitude of the power supply voltage over the range of from $2 V_{DC}$ to $30 V_{DC}$.

It is usually unnecessary to use a bypass capacitor across the power supply line.

The differential input voltage may be larger than V^+ without damaging the device. Protection should be provided to prevent the input voltages from going negative more than $-0.3 V_{DC}$ (at 25°C). An input clamp diode can be used as shown in the applications section.

The output of the LM139 series is the uncommitted collector of a grounded-emitter NPN output transistor. Many collectors can be tied together to provide an output OR'ing function. An output pull-up resistor can be connected to any available power supply voltage within the permitted supply voltage range and there is no restriction on this voltage due to the magnitude of the voltage which is applied to the V^+ terminal of the LM139A package. The output can also be used as a simple SPST switch to ground (when a pull-up resistor is not used). The amount of current which the output device can sink is limited by the drive available (which is independent of V^+) and the β of this device. When the maximum current limit is reached (approximately 16 mA), the output transistor will come out of saturation and the output voltage will rise very rapidly. The output saturation voltage is limited by the approximately $60\Omega R_{SAT}$ of the output transistor. The low offset voltage of the output transistor (1 mV) allows the output to clamp essentially to ground level for small load currents.

Typical Applications ($V^+ = 5.0 V_{DC}$)

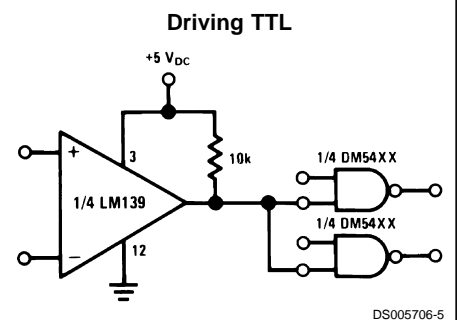
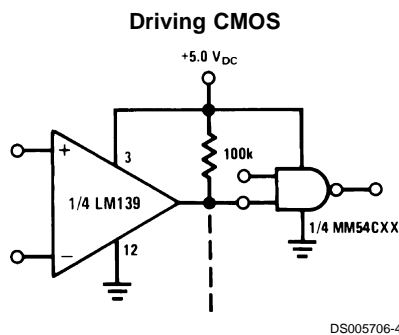
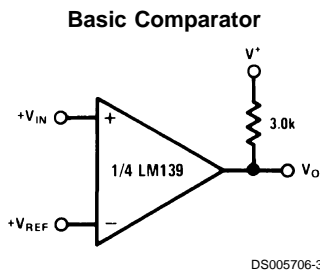

Typical Applications ($V^+ = 5.0 V_{DC}$) (Continued)

AND Gate

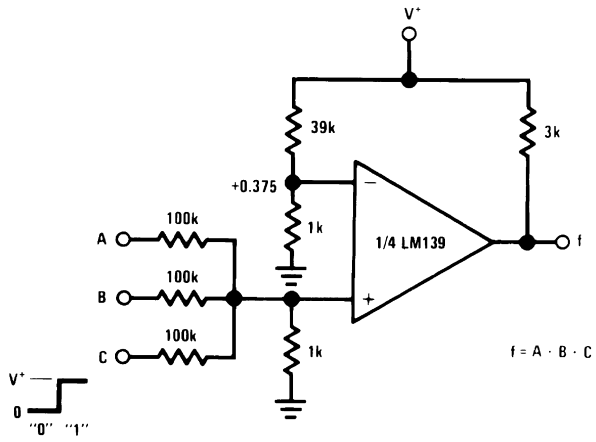

OR Gate

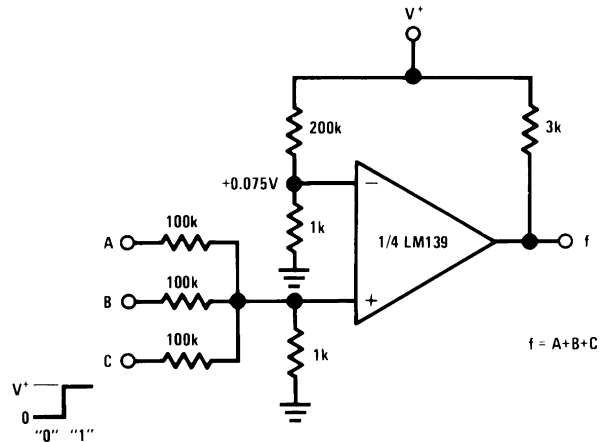

Typical Applications ($V^+ = 15 V_{DC}$)

One-Shot Multivibrator

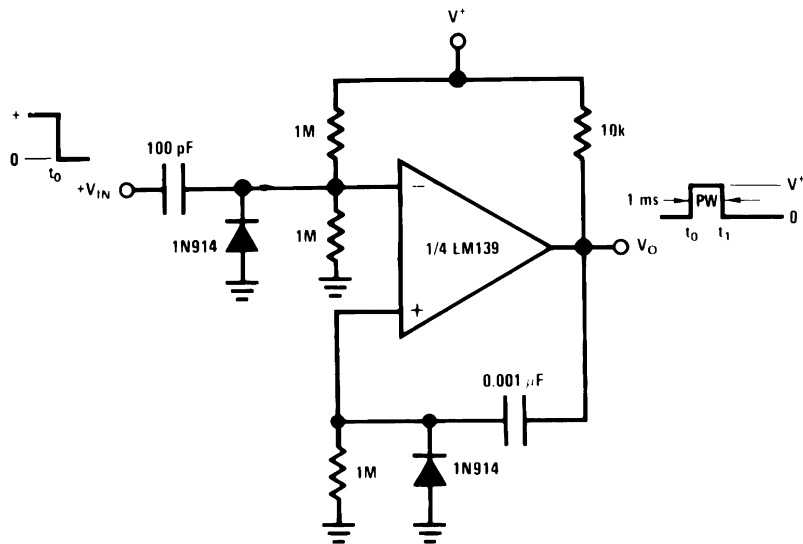

Bi-Stable Multivibrator

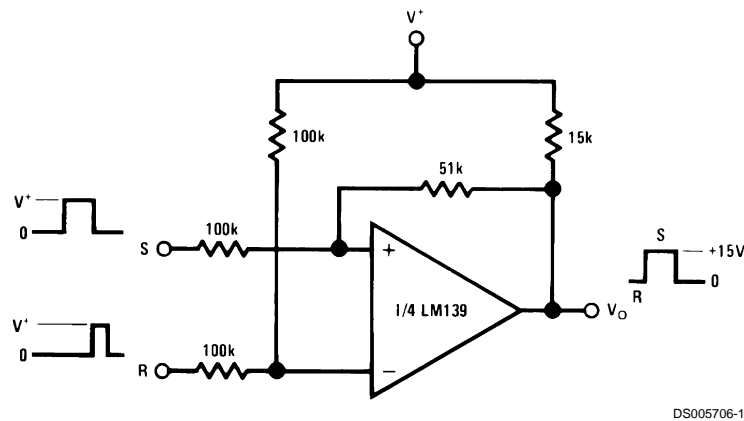

Typical Applications ($V^+ = 15 V_{DC}$) (Continued)

One-Shot Multivibrator with Input Lock Out

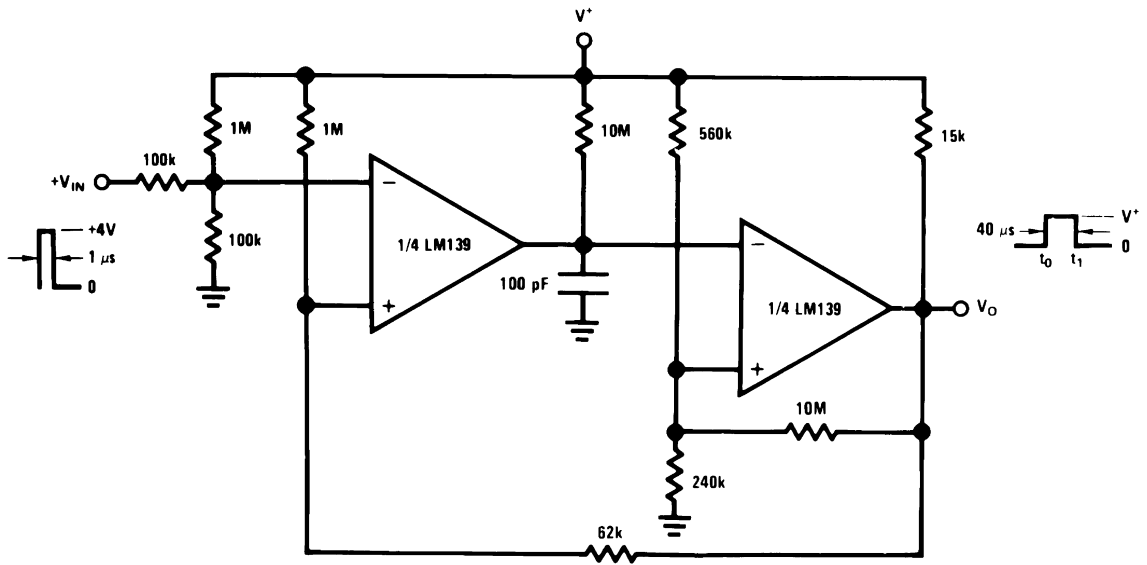

DS005706-12

Pulse Generator

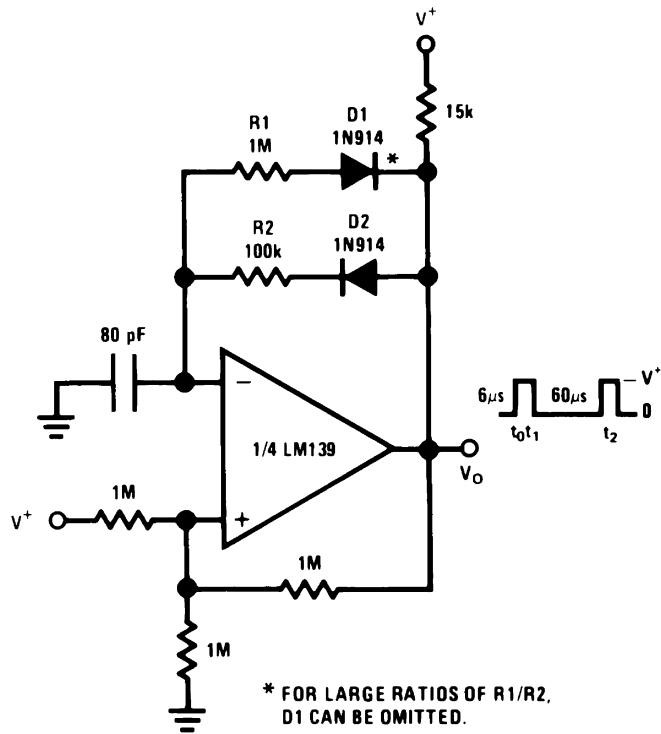

* FOR LARGE RATIOS OF $R1/R2$,
D1 CAN BE OMITTED.

DS005706-17

Typical Applications ($V^+ = 15 V_{DC}$) (Continued)

Large Fan-In AND Gate

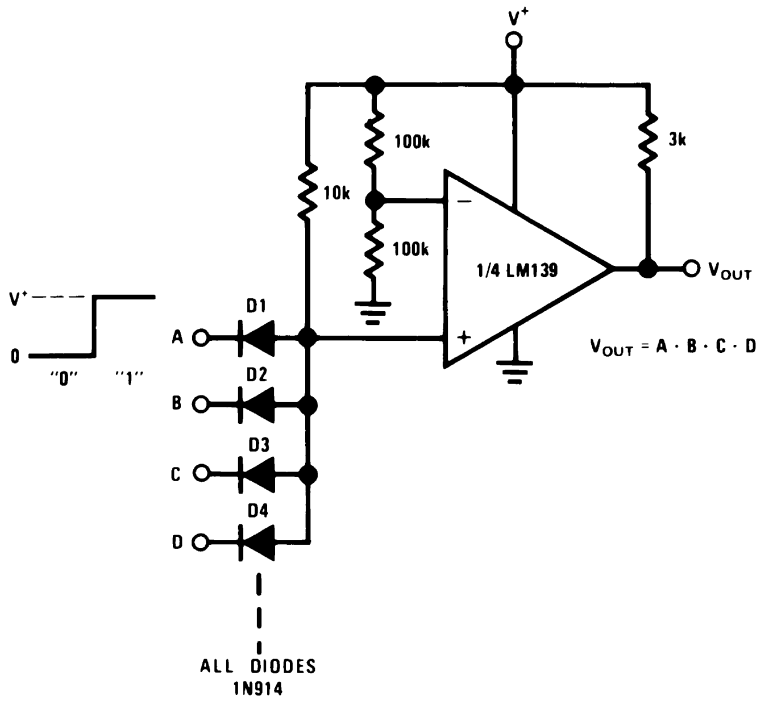

DS005706-13

ORing the Outputs

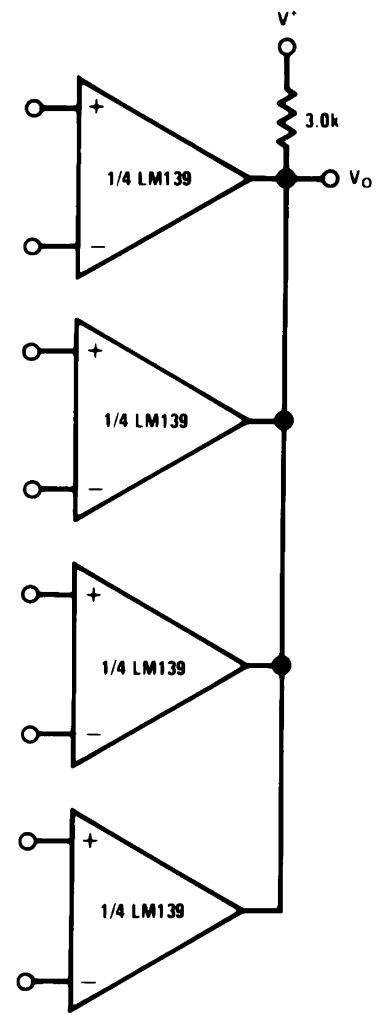

DS005706-15

Typical Applications ($V^+ = 15 V_{DC}$) (Continued)

Time Delay Generator

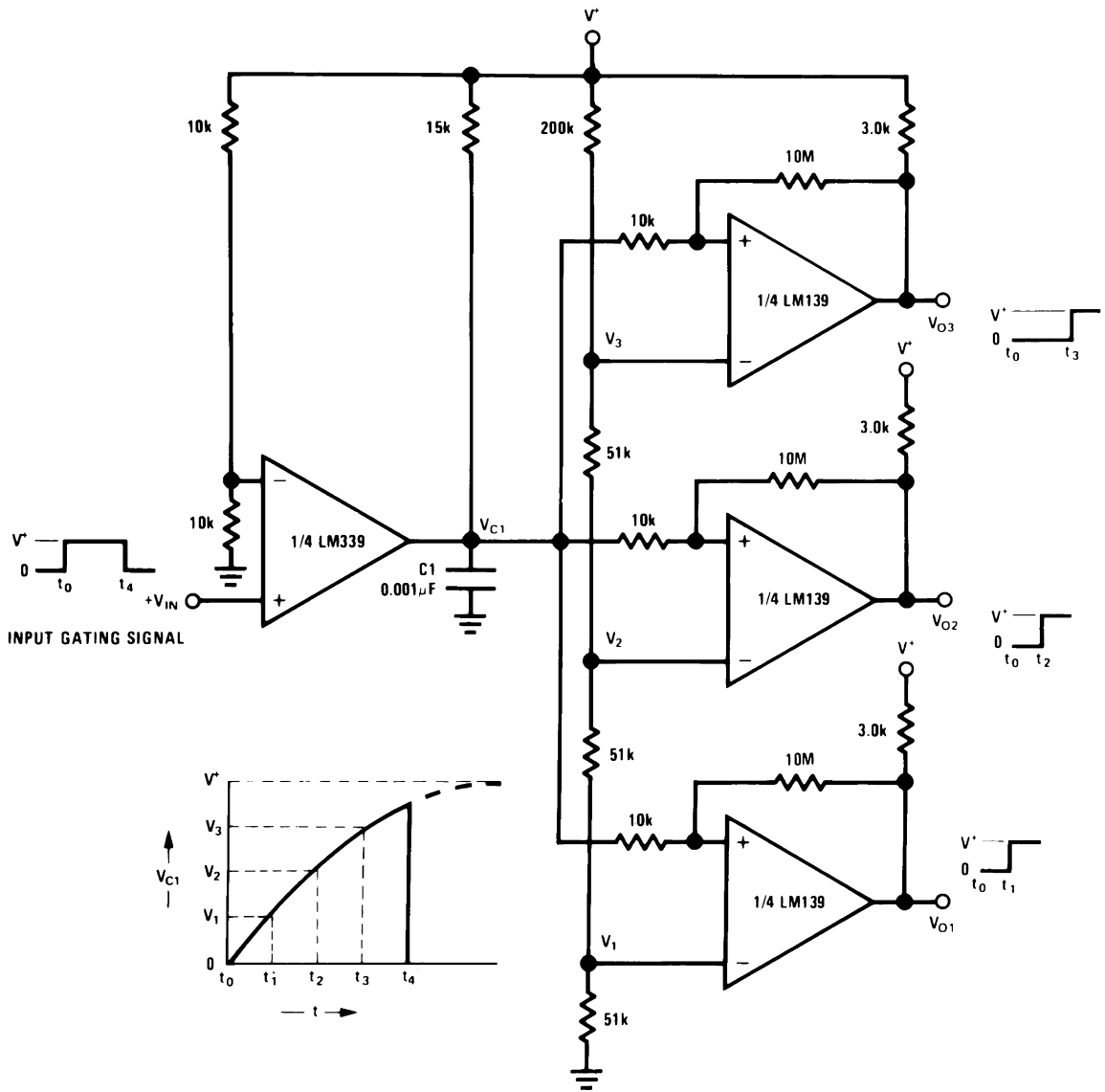

DS005706-14

Non-Inverting Comparator with Hysteresis

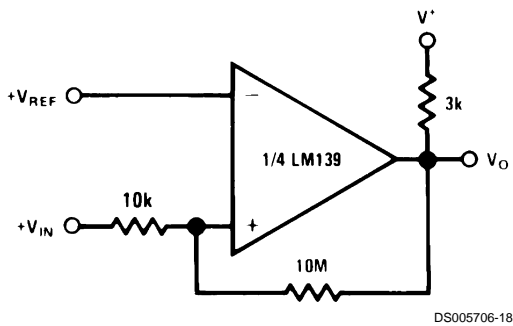

DS005706-18

Inverting Comparator with Hysteresis

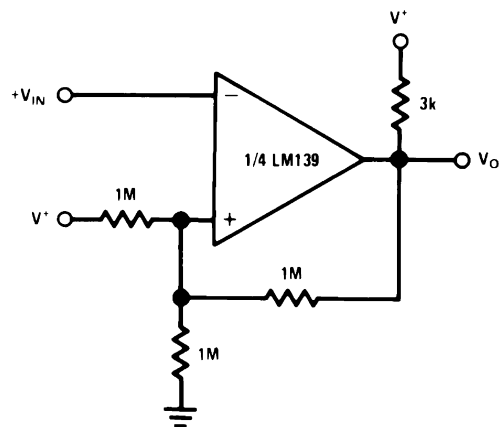

DS005706-19

Typical Applications ($V^+ = 15 V_{DC}$) (Continued)

Squarewave Oscillator

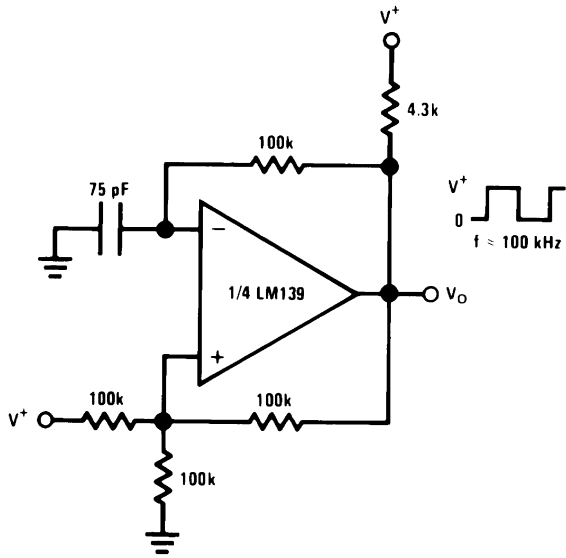

DS005706-16

Basic Comparator

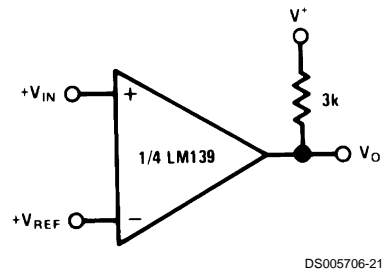

DS005706-21

Limit Comparator

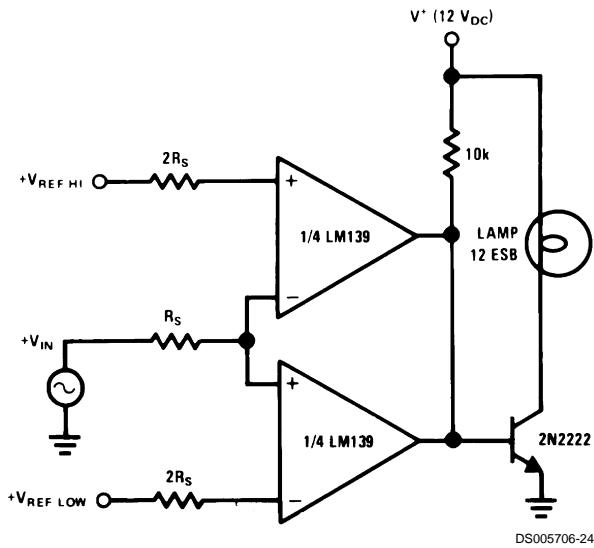

DS005706-24

Comparing Input Voltages of Opposite Polarity

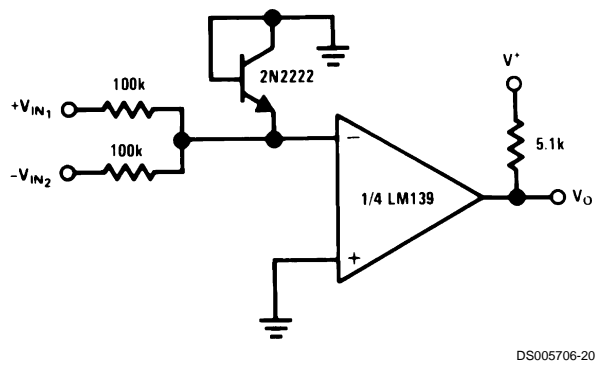

DS005706-20

Typical Applications ($V^+ = 15 V_{DC}$) (Continued)

Output Strobing

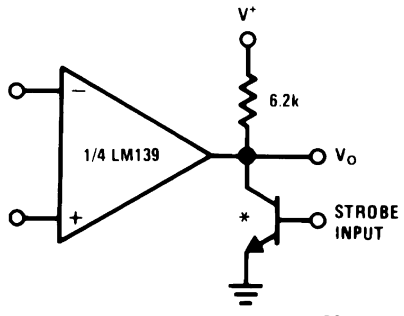

DS005706-22

* Or open-collector logic gate without pull-up resistor

Crystal Controlled Oscillator

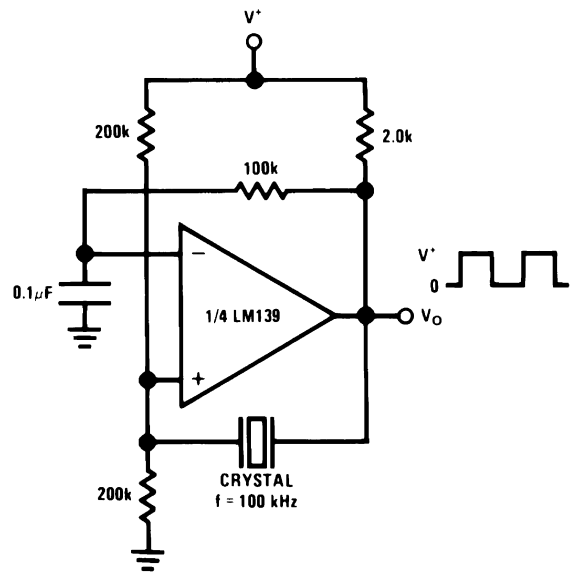

DS005706-25

Typical Applications ($V^+ = 15\text{ V}_{DC}$) (Continued)

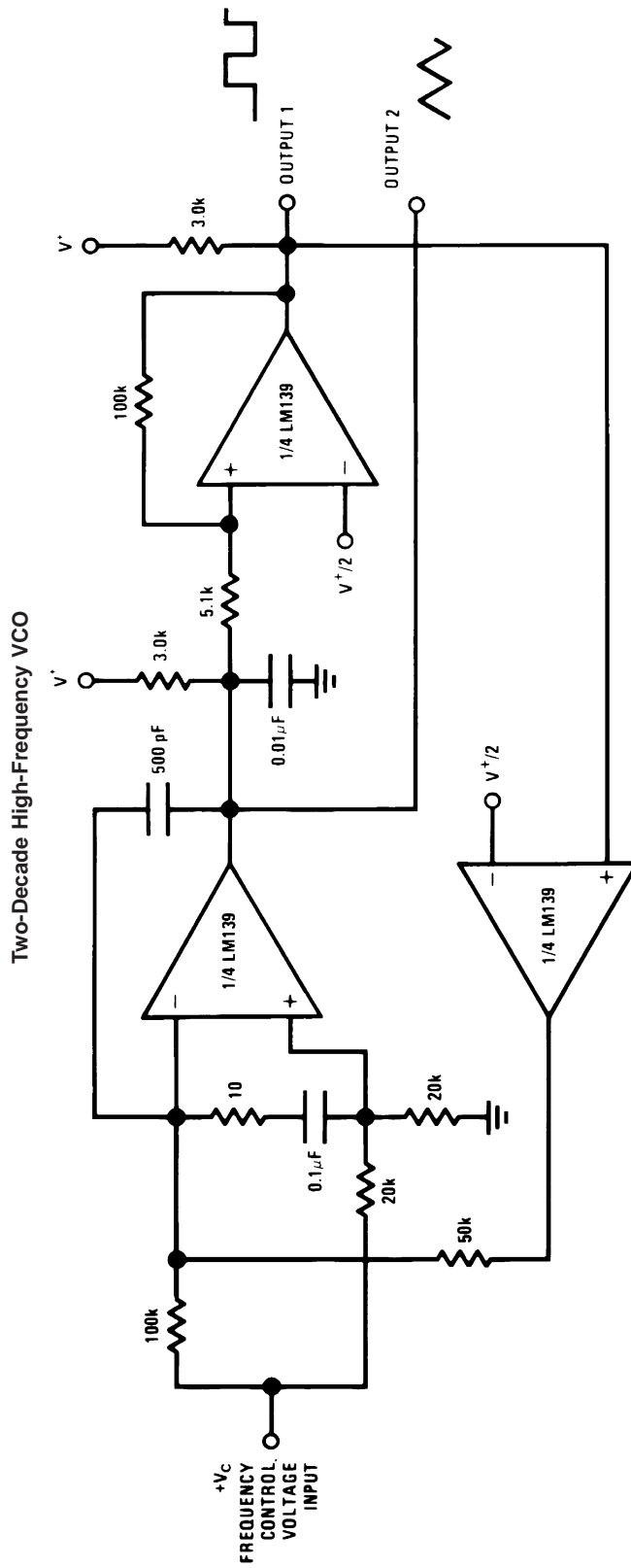

$V^+ = +30\text{ V}_{DC}$
 $250\text{ mV}_{DC} \leq V_{GS} \leq +50\text{ V}_{DC}$
 $700\text{ Hz} \leq f_o \leq 100\text{ kHz}$

DS005706-23

Typical Applications ($V^+ = 15 V_{DC}$) (Continued)

Transducer Amplifier

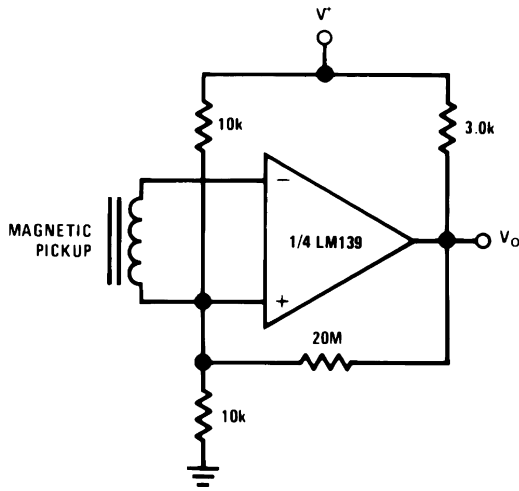

DS005706-28

Zero Crossing Detector (Single Power Supply)

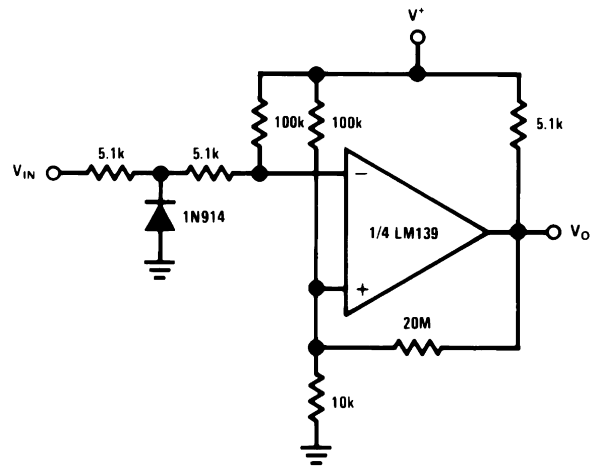

DS005706-30

Split-Supply Applications ($V^+ = +15 V_{DC}$ and $V^- = -15 V_{DC}$)

MOS Clock Driver

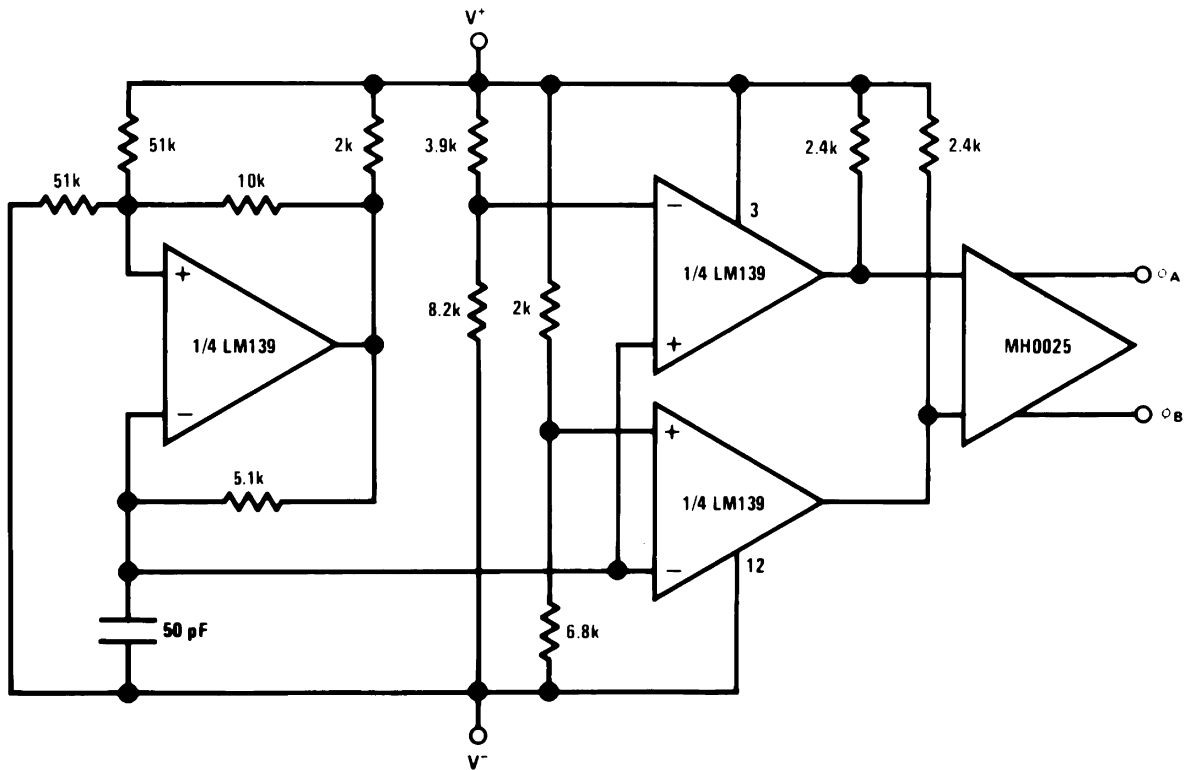

DS005706-31

Split-Supply Applications ($V^+=+15\text{ V}_{DC}$ and $V^-=-15\text{ V}_{DC}$) (Continued)

Zero Crossing Detector

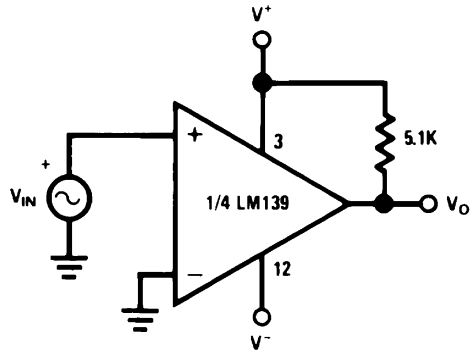

DS005706-32

Comparator With a Negative Reference

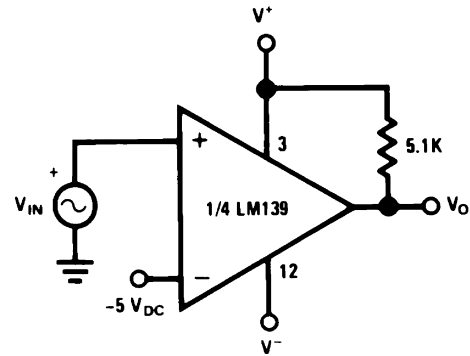

DS005706-33

Schematic Diagram

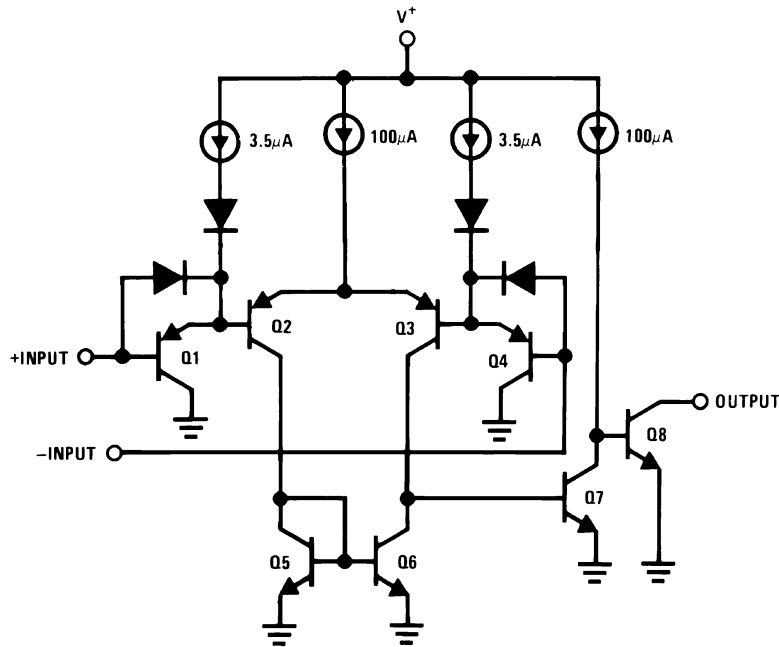

DS005706-1

Connection Diagrams

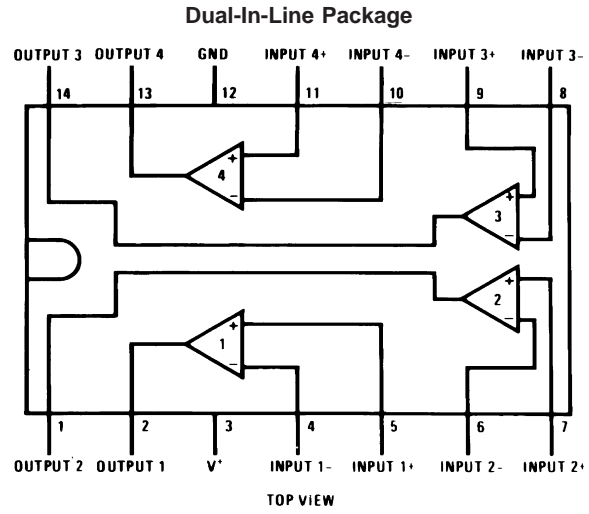

**Order Number LM139J, LM139J/883 (Note 11), LM139AJ,
LM139AJ/883 (Note 12), LM239J, LM239AJ, LM339J**
See NS Package Number J14A

Order Number LM339AM, LM339AMX, LM339M, LM339MX or LM2901M
See NS Package Number M14A

Order Number LM339N, LM339AN, LM2901N or LM3302N
See NS Package Number N14A

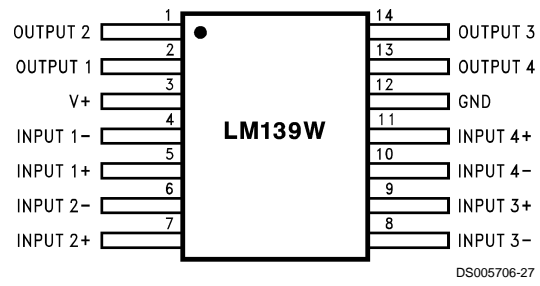

Order Number LM139AW/883 or LM139W/883 (Note 11)
See NS Package Number W14B,
LM139AWGRQMLV (Note 13)
See NS Package Number WG14A

Note 11: Available per JM38510/11201
Note 12: Available per SMD# 5962-8873901
Note 13: See STD Mil Dwg 5962R96738 for Radiation Tolerant Device

Physical Dimensions inches (millimeters) unless otherwise noted (Continued)

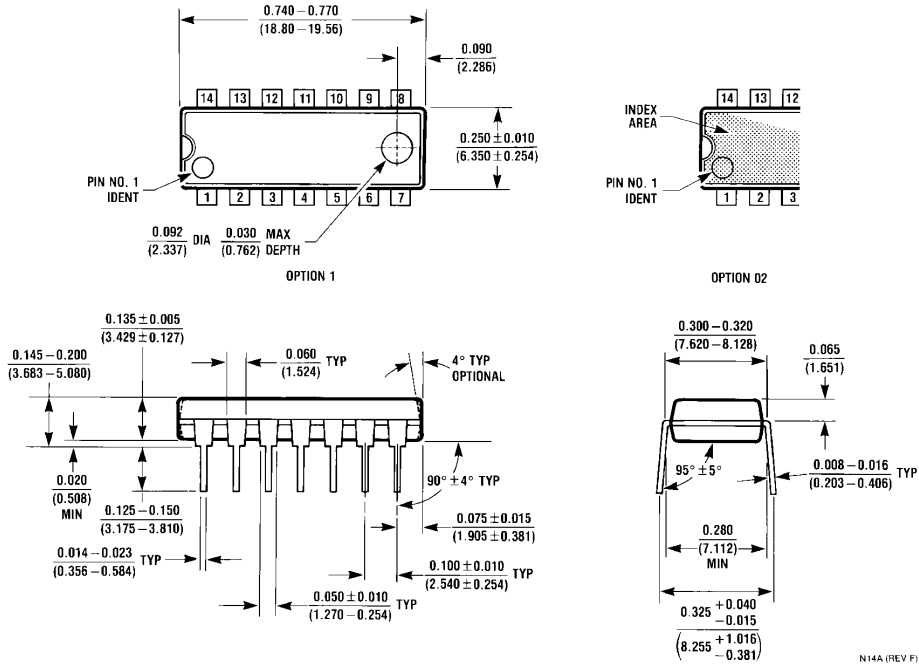

Molded Dual-In-Line Package (N)
Order Number LM339N, LM339AN, LM2901N or LM3302N
NS Package Number N14A

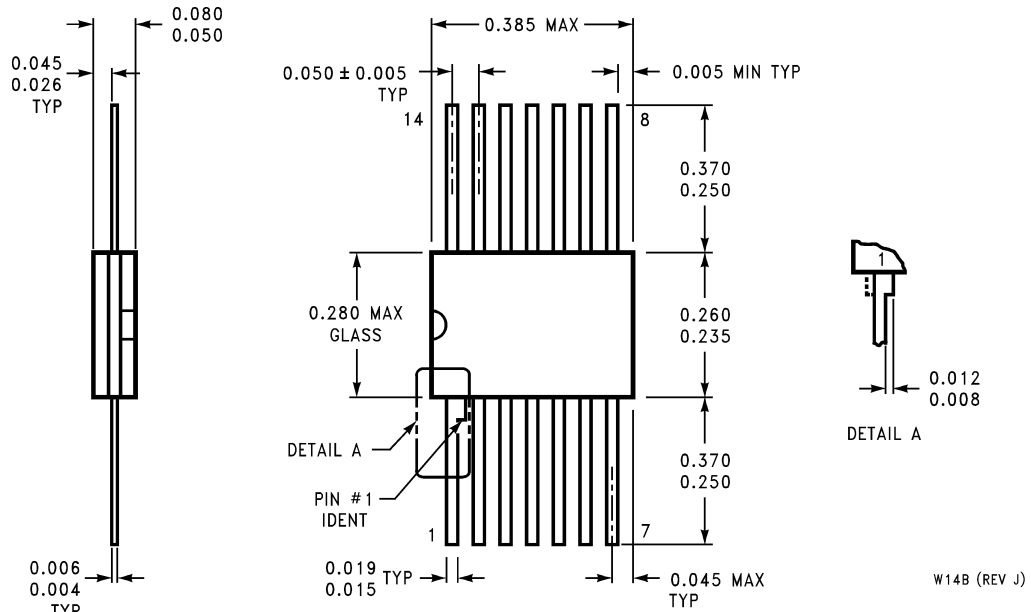

Order Number LM139AW/883, LM139W/883, LM139AWG/883 or LM139WG/883
NS Package Number W14B

Notes

LIFE SUPPORT POLICY

NATIONAL'S PRODUCTS ARE NOT AUTHORIZED FOR USE AS CRITICAL COMPONENTS IN LIFE SUPPORT DEVICES OR SYSTEMS WITHOUT THE EXPRESS WRITTEN APPROVAL OF THE PRESIDENT AND GENERAL COUNSEL OF NATIONAL SEMICONDUCTOR CORPORATION. As used herein:

1. Life support devices or systems are devices or systems which, (a) are intended for surgical implant into the body, or (b) support or sustain life, and whose failure to perform when properly used in accordance with instructions for use provided in the labeling, can be reasonably expected to result in a significant injury to the user.
2. A critical component is any component of a life support device or system whose failure to perform can be reasonably expected to cause the failure of the life support device or system, or to affect its safety or effectiveness.



National Semiconductor Corporation
Americas
Tel: 1-800-272-9959
Fax: 1-800-737-7018
Email: support@nsc.com
www.national.com

National Semiconductor Europe
Fax: +49 (0) 180-530 85 86
Email: europe.support@nsc.com
Deutsch Tel: +49 (0) 69 9508 6208
English Tel: +44 (0) 870 24 0 2171
Français Tel: +33 (0) 1 41 91 8790

National Semiconductor Asia Pacific Customer Response Group
Tel: 65-2544466
Fax: 65-2504466
Email: ap.support@nsc.com

National Semiconductor Japan Ltd.
Tel: 81-3-5639-7560
Fax: 81-3-5639-7507